

# MONOCHROMATORS AND SPECTROGRAPHS

## SMALL SERIES - 9030 MONOCHROMATORS

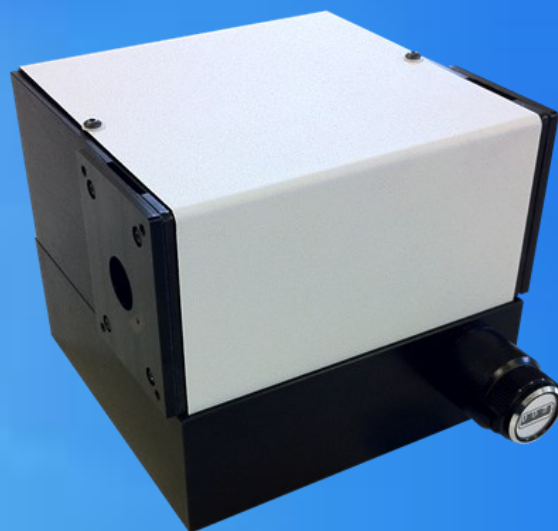

### Features

- High-throughput, aberration-compensated design
- Grating options covering the UV, VIS and NIR spectral ranges
- USB2.0 communication for motorized version
- Fully integrated software and development libraries available

### Applications

- Tunable monochromatic light source
- Spectroscopic systems:
  - Emission and source characterization
  - Absorbance, transmittance and reflectance measurement
  - High dispersion or high power density spectral illumination system
  - Electrochemical spectroscopy
  - Fluorescence spectroscopy
  - Scanning spectrophotometer system
  - Raman spectroscopy



# 9030 SERIES MONOCHROMATORS

## A. Overview

- The Sciencetech 9030 series monochromators are our most economical scanning monochromators. The standard model features a manually controlled wavelength selector and removable, fixed-width slits.
- The compact design features a Seya-Namioka optical layout, using a single concave holographic grating with an f/3.2 aperture. A pair of removable fixed-width slits are included for the input and output ports. Several accessories are available, and an optional external motor drive for computerized control is available.

## B. Specifications - 9030 Series Monochromators

**Table I. General Specifications of 9030 Series Monochromators**

Input Focal Length (mm)	100 (per monochromator)
Output Focal Length (mm)	100 (per monochromator)
Wavelength Selection <sup>‡</sup>	Manual standard, motorized option available
Communication	USB 2.0 with motorized version
Readout Mechanics	Sine Drive
Spectral Range (nm) <sup>†</sup>	Table 3, 4, & 5
Aperture	f/3.2
Maximum Grating Size <sup>§</sup> (mm)	32 x 32
Number of Gratings	1 per monochromator
Grating Types	Concave Holographic
Grating Selection	Table 6
Mirror Types	UV-Enhanced Aluminum or Protected Aluminum
Optical Resolution (nm) <sup>†</sup>	Table 3, 4 & 5
Stray Light	Table 3, 4, & 5
Dispersion <sup>†</sup> (nm/mm)	Table 3, 4, & 5
Wavelength Accuracy <sup>†</sup> (± nm)	1.0
Wavelength Reproducibility <sup>†</sup> (± nm)	0.25
Optical Axis Height (mm)	76.2
Compatible Detector Types	Single Channel
Dimensions (mm)	Table 2
Weight (kg)	Table 2

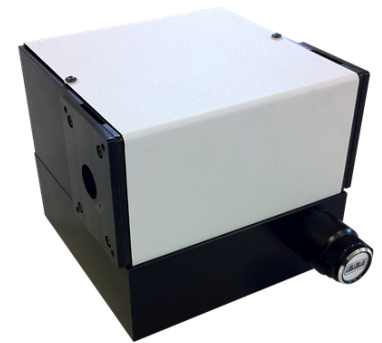

**9030 Single Monochromators**



**9030 Double Monochromators**

<sup>†</sup> Grating dependent; <sup>‡</sup> With readout counter (0.1nm); <sup>§</sup> Substrate size. Active area is 30 x 30 mm.

# 9030 SERIES MONOCHROMATORS

**Table 2. Dimension and Weight of 9030 Series**

Model	Width	Depth	Height	Optical Height	Weight
Single Monochromators	12.5 cm	12.6 cm	10.4 cm	7.6 cm	2 kg
	5.0 in	4.9 in	4.1 in	3.0 in	
Double Monochromators	26.0 cm	12.6 cm	10.4 cm	7.9 cm	4.5 kg
	10.2 in	4.9 in	4.1 in	3.1 in	

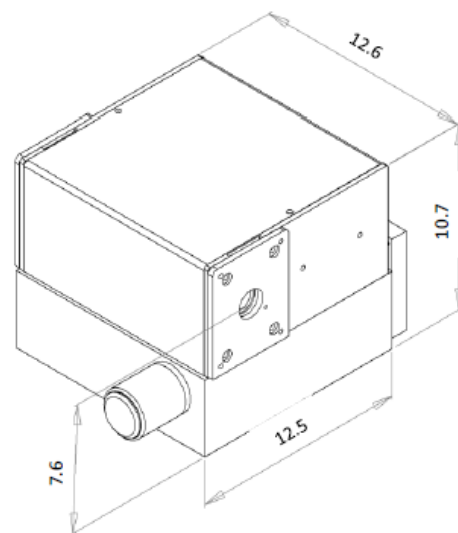

- The dimension of 9030DA/DS is approximately double the single unit dimension of 9030.
- CAD models of Scientech standard monochromators are available upon request. Please [contact](#) our application scientist team for more information.

## B. I. Specifications - Single Monochromators

**Table 3. 9030 Single Monochromators**

Model	9030-UVVIS	9030-VISNIR
Part Number	120-9016	120-9003
Spectral Range (nm) <sup>†</sup>	250-700nm	500-2000nm
Grating Selection	Refer to Table. 6	Refer to Table. 6
Mirror Types	UV Enhanced Aluminum	Protected Aluminum
Optical Resolution (nm) <sup>‡</sup>	< 1	< 1
Stray Light	10E-4	10E-4
Dispersion <sup>§</sup> (nm/mm)	8	8

<sup>†</sup> Grating dependent; <sup>‡</sup> With readout counter (0.1nm); <sup>§</sup> Substrate size. Active area is 30 x 30 mm.

# 9030 SERIES MONOCHROMATORS

## B.2. Specifications - Double Monochromators

- For applications requiring better signal to noise, reduced stray light and better resolution than the standard model a double additive model (9030DA) is available. For applications requiring a tunable bandpass light source the double subtractive model (9030DS) is an ideal choice.

**Table 4. 9030DA Monochromators**

Model	9030DA-UVVIS	9030DA-VISNIR
Part Number	120-9080	120-9029
Spectral Range (nm) <sup>†</sup>	250-700nm	500-2000nm
Grating Selection	Refer to Table. 6	Refer to Table. 6
Mirror Types	UV Enhanced Aluminum	Protected Aluminum
Optical Resolution (nm) <sup>†</sup>	0.5	0.5
Stray Light	10E-7	10E-7
Dispersion <sup>†</sup> (nm/mm)	4	4

<sup>†</sup> Grating dependent; <sup>‡</sup> With readout counter (0.1nm); <sup>§</sup> Substrate size. Active area is 30 x 30 mm.

**Table 5. 9030DS Monochromators**

Model	9030DS-UVVIS	9030DS-VISNIR
Part Number	120-9081	120-9015
Spectral Range (nm) <sup>†</sup>	250-700nm	500-2000nm
Grating Selection	Refer to Table. 6	Refer to Table. 6
Mirror Types	UV Enhanced Aluminum	Protected Aluminum
Optical Resolution (nm) <sup>†</sup>	1 nm bandpass	1 nm bandpass
Stray Light	10E-7	10E-7
Dispersion <sup>†</sup> (nm/mm)	<4	<4

<sup>†</sup> Grating dependent; <sup>‡</sup> With readout counter (0.1nm); <sup>§</sup> Substrate size. Active area is 30 x 30 mm.

[Browse Small Series Monochromators on the Sciencetech Website](#)

# 9030 SERIES MONOCHROMATORS

## C.1. Double Subtractive (DS) Monochromator Configuration

The 9030DS (Double Subtractive) is made of 2 back-to-back 9030 monochromators in a **subtractive** mode: the dispersion of the second monochromator is in the opposite direction of that of the first one. The gratings are calibrated to rotate synchronously in opposite directions. Stray light is drastically reduced in a double monochromator, and in the 9030DS it is further minimized by the use of concave holographic gratings. This makes the 9030DS an ideal instrument for applications where stray light is a problem, such as in spectroradiometry, Raman or UV measurements of solar radiation. The 9030DS can act either as a tunable bandpass filter or a tunable notch filter. The Model 9030DS can also be used to pass or filter out several selected wavelengths by using a custom intermediate multi-slit mask instead of a single width intermediate slit.

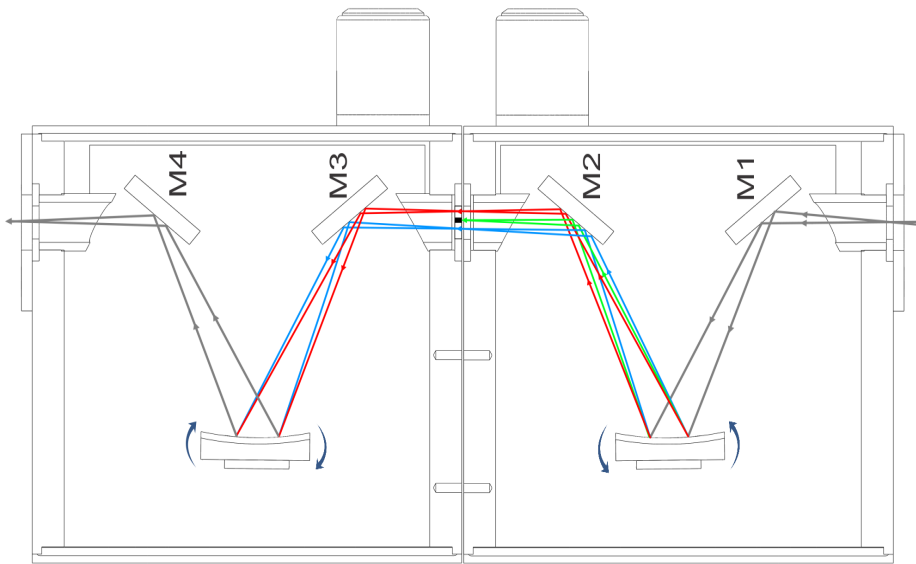

## C.2. Double Additive (DA) Monochromator Configuration

The 9030DA (Double Additive) is made of 2 back-to-back 9030 monochromators in an **additive** mode: the dispersion of the second monochromator adds to that of the first one. The gratings are calibrated to rotate synchronously in the same direction. The inbound light is dispersed by the first grating then passes through an intermediate slit where stray light is rejected and then spectrally dispersed again by the second grating. The double dispersion of 9030DA results in a better optical resolution compared to a single 9030 monochromator while the bandpass is half that of a single 9030. The diffraction gratings in the 9030DA are mechanically connected and calibrated for accurate wavelength tracking. The 9030DA can be motorized with the addition of a motor drive system.

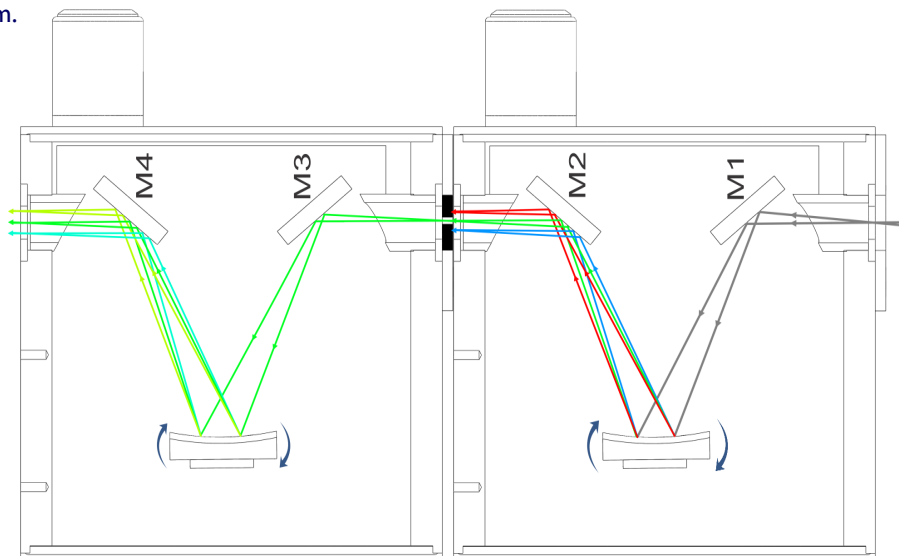

**Note:** The 9030DS and 9030DA can be motorized with the addition of a motor drive system. Only one motor and one drive system is required, enabling control via user-friendly software provided by Sciencetech.

# 9030 SERIES MONOCHROMATORS

## D. Accessories

### 1) Grating selection

There are three basic parameters to consider when choosing a grating for your monochromator.

- **Required Wavelength Range**

The wavelength range available to you is determined by the grating groove density chosen and the angular mechanical limitation of the monochromator.

- **Grating Efficiency**

Ruled gratings may be blazed to increase their efficiency over a specific wavelength band. Holographic gratings can be modulated such that they are more efficient at some wavelengths than at others. Grating efficiency curves are the best tool for determining the most efficient grating available for your application.

It is important to note that grating efficiency curves do not represent the exact efficiency that should be expected when the grating is used in a monochromator as grating efficiency curves are taken at Littrow angle.

- **Required Resolution and Bandwidth**

Resolution is a measure of an instrument's ability to separate adjacent spectral lines. Resolution is generally given in nm. The bandwidth (or bandpass) is the wavelength range that falls on the output port at any one time and is also given in nm.

**Table 6. Grating selection**

Grating Selection Guide for 9030 Series					
Grating Model #	630-0009	630-0038	630-0008	630-0022	630-0035
Grating (l/mm)	1200	1200	1200	600	800
Blaze Wavelength	250	350	450	N/A	N/A
Dispersion (nm/mm)	8	8	8	16	12
Resolution (nm)	< 1	< 1	< 1	< 2	< 2
Spectral Range (nm)	200-600	325-700	400-1000	400-1600	300-1200
Compatible Monochromators	9030-UVVIS 9030DA-UVVIS 9030DS-UVVIS	9030-UVVIS 9030DA-UVVIS 9030DS-UVVIS	9030-VISNIR 9030DA-VISNIR 9030DS-VISNIR	9030-VISNIR 9030DA-VISNIR 9030DS-VISNIR	9030-VISNIR 9030DA-VISNIR 9030DS-VISNIR

[Browse Gratings on the Sciencetech Website](#)



### 2) Slit assembly options

Slits are included with the purchase of a 9030 or 9030 DA/DS system. Generally, input and output slits are chosen with the same slit width. The intermediate slit for a 9030DA or DS system may be different from the input and output slits. Notch filters are not included and are usually custom made depending on application. Sciencetech can manufacture custom slits. Please talk to a technical support representative about your custom requirements.

# 9030 SERIES MONOCHROMATORS

**Note: SS-80 adjustable slits are not compatible with 9030 monochromator**

**Table 7. Available slits for 9030 series**

Fixed Slit Options	
Model	Slit Selection*
9030	Choose 2 slits
9030DS / DA	Choose 3 slits

\* slits will be added at zero cost to your order

Part Number	Model	Description
120-9033	SF01-0.1MM	Removable 100µm (0.1mm) Fixed Width Slit
120-9013	SF025-0.25MM	Removable 250µm (0.25mm) Fixed Width Slit
120-9012	SF05-0.5MM	Removable 500µm (0.5mm) Fixed Width Slit
120-9011	SF1-1MM	Removable 1mm Fixed Width Slit
120-9010	SF2-2MM	Removable 2mm Fixed Width Slit
120-9034	SF2-3MM	Removable 3mm Fixed Width Slit

### 3) 9030 motorized control option

Sciencetech 9030 series monochromators use a precision sine drive system to rotate the grating for wavelength selection. This sine drive maintains a linear correlation between wavelength selected and readout counter which is essential in a manual control system. With the optional motor drive, the precision sine drive system is maintained and the rotation is performed by a computer-controlled stepper motor. A Windows-based Active-X control module (Sci-Mono) is included with the optional motor drive so the wavelength can be selected through software. The Active-X control module can be used as stand-alone control software, or through a more sophisticated software application such as LabView. Sci-Spec, Sciencetech's standalone data acquisition and monochromator control software is available at an additional cost. Sci-Spec automatically coordinates motorized wavelength scanning actions and data acquisition from a suitable detector mounted at the monochromator output port. Sci-Spec can also coordinate other hardware such as automatic filter wheel selection. For more information about [Sci-Spec](#) see the Sciencetech website.

Motorized Control Options		
Part Number	Model	Description
120-9027	-USB	Motorization option with USB 2.0 interface

[Browse Configuration Options on the Sciencetech Website](#)



## E. Custom & OEM

Sciencetech has built its reputation on custom solutions. Whether you need a small modification to an existing system or a completely novel design built from the ground up to meet your technical specifications, Sciencetech's engineering and optical design teams are ready to help.

Sciencetech OEM Division is ready to assist original equipment manufacturers with standard or custom monochromators to suit their equipment.

1450 Global Drive, London, Ontario Canada, N6N 1R3  
 Phone: 519 644 0135 / Fax: 519 644 0136  
 Email: [sales@sciencetech-inc.com](mailto:sales@sciencetech-inc.com)  
[www.sciencetech-inc.com](http://www.sciencetech-inc.com)

