

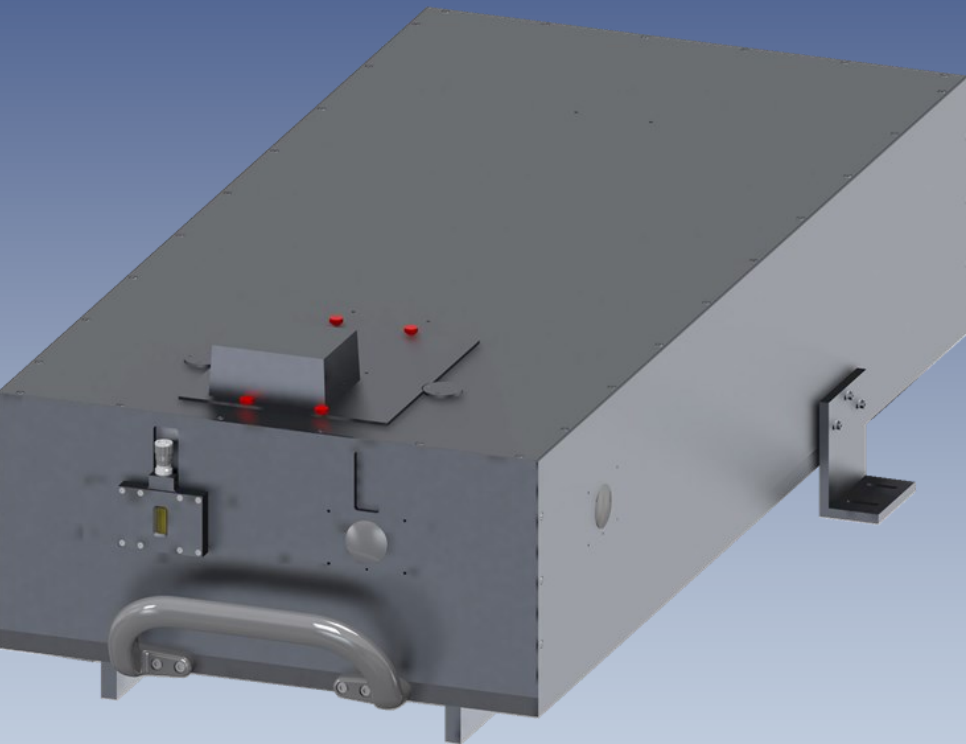

TDB 41.5



## Features

- Highly Customizable Modular Design
- Two Configurable Input and Output Ports
- Configurable turret and Grating Options
- USB2.0 Communication
- A Full Line of Input and Output Accessories
- Fully Integrated Software and Development Libraries Available

# High Resolution Series Monochromators



# High Resolution Series Monochromators

## ORDERING INFO

9### - (EF) - #G - (\*\*)

1
2
3
4

1	
Model Name	
9040	0.5 meter focal length
9490	1.0 meter focal length
9150	1.5 meter focal length

2	
Mirror Size –Affects F/#	
-	75x75mm Concave Mirrors
F	90x90mm Concave Mirrors
EF	110x110mm Concave Mirrors

3	
Turret Configuration	
1G	Single Grating, Manual Selection
3G	Triple Grating, Computer Controlled

4	
Other Options	
-DP	With Dual Pass Option
-CM	Wide Camera Mirror
-UV/S/G	Mirror Coating Options
-DS	Double Subtractive System*
-DA	Double Additive System*

# High Resolution Series Monochromators

## SPECIFICATIONS

Model #	9040	9490	9150
Communication	500	914	1500
Output Focal Length (mm)	550	1000	1500
Wavelength Selection	Motorized	Motorized	Motorized
Communication	USB 2.0	USB 2.0	USB 2.0
Readout Mechanics	Sine Drive	Sine Drive	Sine Drive
Spectral Range*	Varies with Grating Selection		
Aperture	F/4.0, F/5.2 F/6.9	F/7.4, F/9.7, F/13.0	F/12
Maximum Grating Size (mm x mm)	110mm x 110mm	110mm x 110mm	110mm x 110mm
Number of Gratings	Up to 3	Up to 3	Up to 3
Optical Resolution**	0.03	0.017 (0.009 for DP)	0.013 (0.0063 for DP)
Stray Light	4 E-4	4 E-4	4 E-4
Double Pass Option	NO	YES	YES
Dispersion* (nm/mm)	1.53 (0.75 DA)	0.83 (0.42 DP)	0.5 (0.25 DP)
Wavelength Accuracy* (+ nm)	0.05	0.03	0.02
Wavelength Reproducibility* (+ nm)	0.025	0.01	0.002
Flat Field Size (mm)	30 x 12	27 x 12	27 x 12
Flat Field Angle (deg)	-0.735	0.3	0.3
Optical Axis Height (mm/in)	139	200.5	200.5
Dimensions (mm)	711 x 381 x 254	1120 x 560 x 360	1600 x 572 x 381
Dimensions (in)	28 x 15 x 10	44 x 22 x 14	63 x 22.5 x 15
Weight (kg)	35	115	150
Power Consumption	24V/60W	24V/60W	24V/60W

[Browse High Resolution Series Monochromators on the Sciencetech Website](#)

\* Specifications given for 1200l/mm gratings with 25um wide input slit

\*\* Resolution for F/6.9 and F/13 on 9040 and 9490 Models

\*\*\* Note that the addition of powered accessories will increase the power consumption



# High Resolution Series Monochromators

## SPECIFICATIONS

### Optical Configuration

The size of mirror and gratings used in the monochromator determine its F/#. With decreasing F/# the monochromator will collect more light. It is possible to use different sized gratings and mirrors in the same monochromator however system throughput will be dictated by the smallest optic in the monochromator.

F/# Options			
Model	F/#	Nominal Grating Size (mm x mm)	Available Turret Configurations
9040	F/6.9	64 x 64	1G, 3G
9040F	F/5.2	84 x 84	1G, *
9040EF	F/4.0	102 x 102	1G *
9490	F/13	64 x 64	1G, 3G
9490F	F/9.7	84 x 84	1G, 3G
9490EF	F/7.4	102 x 102	1G, 3G
9150	F/12	102 x 102	1G, 3G
9150X	Call	Call	Echelle

### Turret Configuration

A number of turret configurations are available. Some turret configurations are not available in some monochromators due to mechanical limitations.

#### 1G Turrets

Single grating turrets allow for manual grating selection. Each grating is mounted on a kinematic grating holder

1G, Single Grating Turrets: Manual Grating Selection

Part #	Grating Size (mm x mm)	Number of Gratings
120-8039	64 x 64	1
120-8040	84 x 84	1
120-8041	102 x 102	1



#### 3G Turrets

3G turrets allow for motorized grating selection. Up to 3 gratings are mounted on a cassette. The cassette rotates perpendicularly to the axis of rotation of the sine drive. The cassette can be replaced with other cassettes allowing for unlimited grating options

3G, Motorized Turrets allow for computer controlled grating selection:

Part #	Grating Size (mm x mm)	Number of Gratings
120-8056	64 x 64	3
120-8057	84 x 84	3
120-8058	102 x 102	3

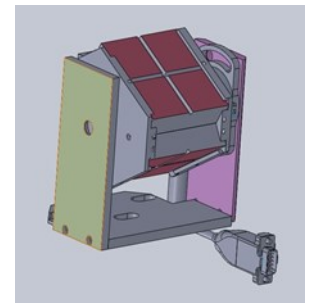

# High Resolution Series Monochromators

## CONFIGURATION

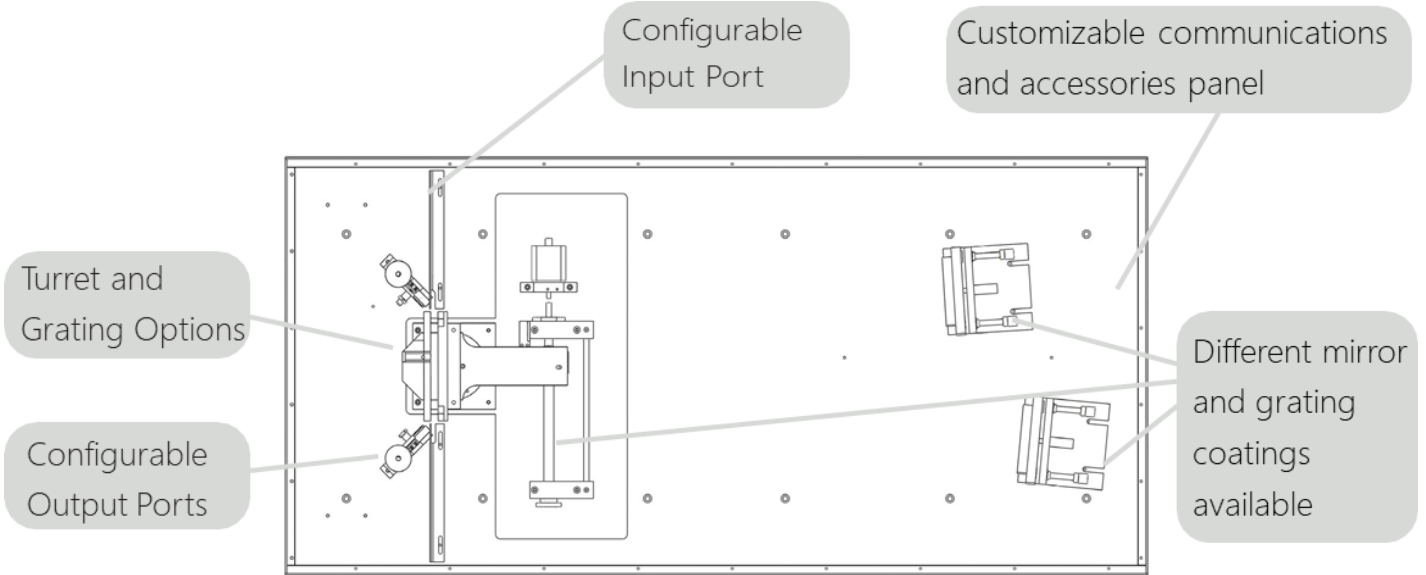

Step 2: Input Port		
Configuration		
Part #	Model	Description
120-8044	9000-HI-IN	Fixed Side Input Port
120-8032	DPIN-HI-MAN	Manual Dual Input Port
120-8072	DPIN-HI-MOT	Motorized Dual Input Port

Step 3: Output Port		
Part #	Model	Description
120-8045	9000-HI-OUT	Fixed Side Output Port
120-8033	DPOUT-HI-MAN	Manual Dual Output Port
120-8076	DPOUT-HI-MOT	Motorized Dual Output Port

\* 3G available only for 64x64mm grating size

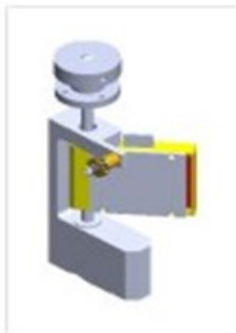

# High Resolution Series Monochromators

## CONFIGURATION

### Step 4: Grating Selection

There are three basic parameters to consider when choosing a grating for your standard series monochromator

#### A) Required Wavelength Range

The wavelength range available to you is determined by the grating groove density chosen and the angular mechanical limitation of the monochromator.

#### B) Grating Efficiency

Ruled gratings may be blazed to increase their efficiency over a specific wavelength band. Holographic gratings can be modulated such that they are more efficient at some wavelengths than at others. Grating efficiency curves are the best tool for determining the most efficient grating available for your application. It is important to note that grating efficiency curves do not represent the exact efficiency that should be expected when the grating is used in a monochromator as grating efficiency curves are taken at Littrow angle.

#### C) Required Resolution and Bandwidth

Resolution is a measure of an instrument's ability to separate adjacent spectral lines. Resolution is generally given in nm. The bandwidth (or bandpass) is the wavelength range that falls on the output port at any one time and is also given in nm. This is an important parameter when integrating a camera such as a linear array or CCD on the output port of the monochromator.

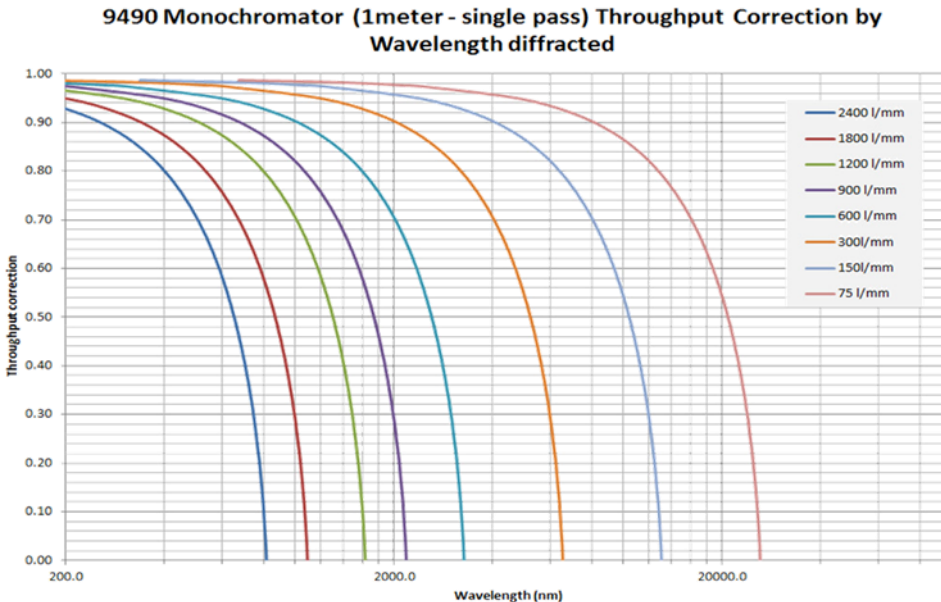

#### Application Note:

For Raman and when a laser is present ensure you choose a holographic grating.

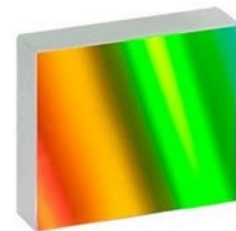

[Browse Gratings on the Sciencetech Website](#)

# High Resolution Series Monochromators

## CONFIGURATION

### Step 5: Mirror and Grating Coatings

Standard mirror coatings are aluminum with a MgF<sub>2</sub> protective layer. Standard gratings have an aluminum coating, metallic coating. If your application would benefit from different mirror or grating coatings please refer to the codes below at the time of order.

Mirror or Grating Coating	Useful Range	Code
Aluminum (MgF <sub>2</sub> coating)	350nm +	Standard
UV enhanced Aluminum	200nm +	-UV
Silver	400nm +	-S
Gold	600nm – Far IR, best option for NIR	-G

### Step 6: Imaging Option

Standard Czerny-Turner type monochromators suffer from astigmatism in the output beam due to the use of off-axis spherical mirrors. Often the astigmatism is not an issue. For imaging applications a torroidal mirror is used to compensate for the inherent astigmatism in the optical system produce a direct image of the input slit at the output port. This is an important option for studying phenomena such as fast kinetics.

Call or [email](#) a technical support representative for more information about this option.

Need something that you don't see here?

Sciencetech has built our reputation on custom solutions. Whether you need a small modification to an existing system or a completely novel design built from the ground up to meet your technical specifications, Sciencetech's engineering and optical design teams are read to help.

[Browse Gratings on the Sciencetech Website](#)

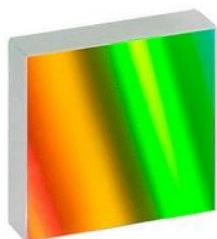

# High Resolution Series Monochromators

## CONFIGURATION

### Dual Pass Option (-DP)

This option adds the double pass option to a 9490 or 9150 monochromator. With the double pass option the reciprocal linear dispersion of the monochromator can be effectively reduced by a factor of two.

By reducing the dispersion the ultimate resolution achievable by the monochromator can also be reduced by a factor of two.

The double pass system functions by introducing pick off mirrors near the entrance and exit ports of the monochromator. The pick off mirrors collect the light that has made a single pass through the monochromator system (collimating mirror, grating and camera mirror) and redirecting the light to make a second pass.

Monochromators with the double pass option included can also be used in single pass. To utilize the single pass option the double pass mirrors are lowered out of the way. Both motorized and manual options are available to move the double pass mirrors into and out of position. In single pass mode the light being redirected into the monochromator is usually sent in along the optical axis. When using the double pass option the entrance light must be sent in parallel to the optical axis and vertically translated by ~6mm. The vertical translation allows the double pass optics to effectively collect and redirect the single pass light. The double pass beam will exit the monochromator vertically translated from the optical axis by the same amount that the light is sent into the monochromator.

The double pass option is only available when using the monochromator front entrance and exit ports. The double pass option may be used with a camera, however the camera should be mounted such that it is vertically translated from the optical axis such that the double pass light will fall on the center of the camera's active area.

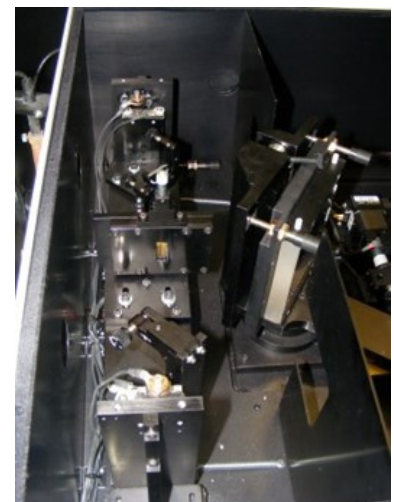
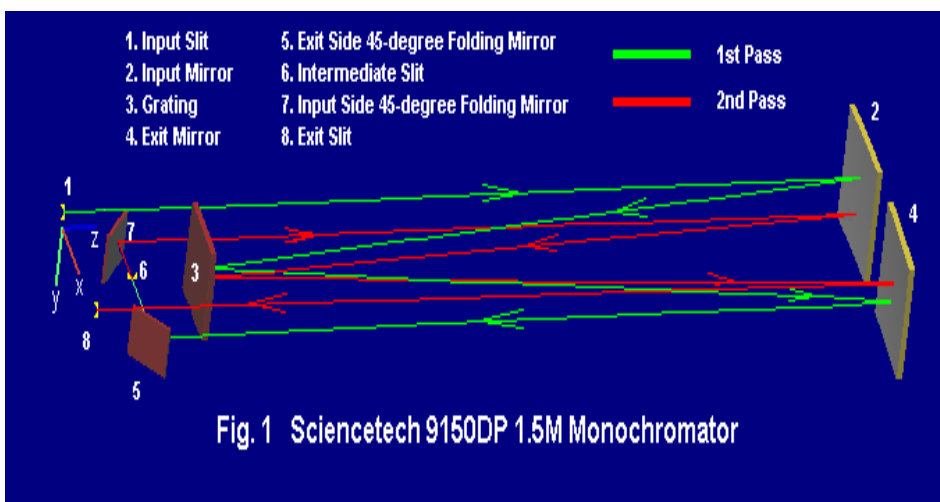



# High Resolution Series Monochromators

## ACCESSORIES

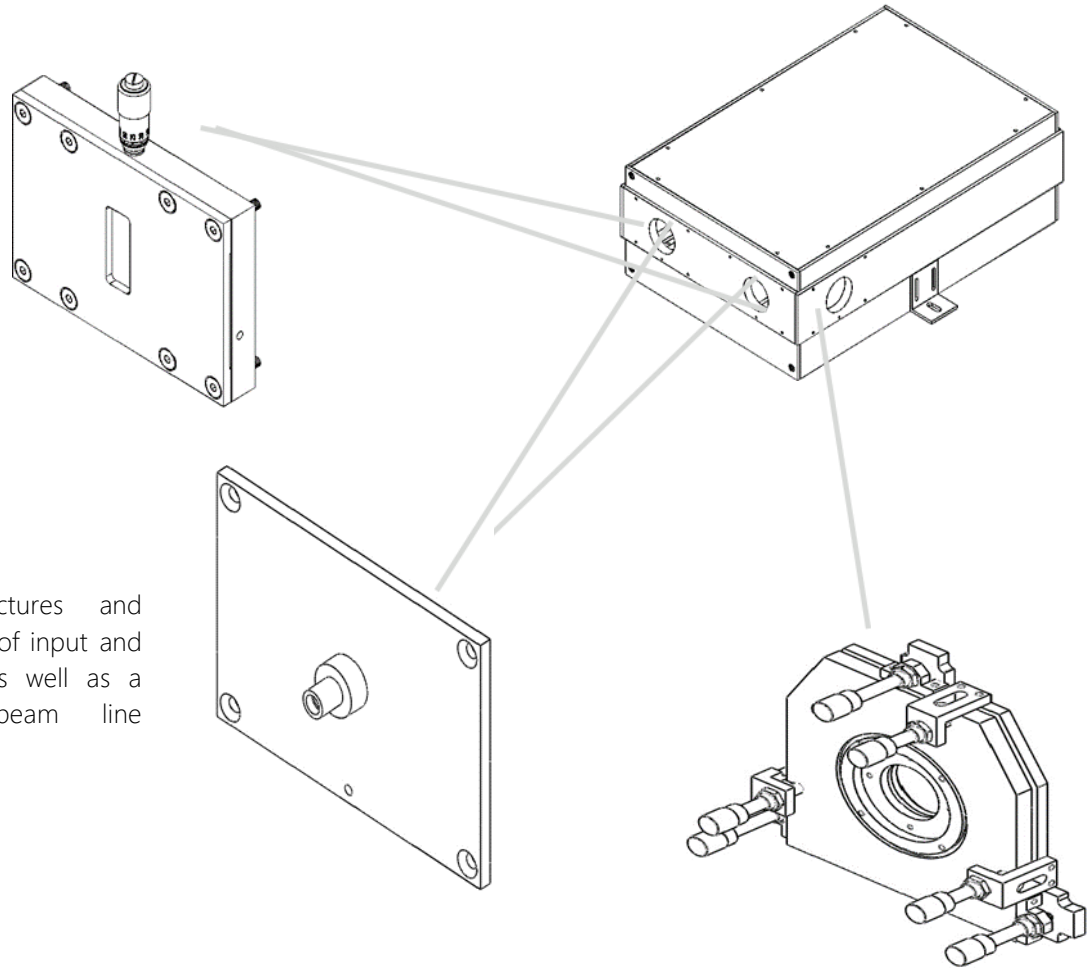

Sciencetech manufactures and integrates a full line of input and output couplings as well as a selection of beam line connections.

Visit our website to look at all the possibilities!

- Slit Assemblies
- Adapters and Connectors
- Optical Choppers
- Sample Chambers
- Manual and Motorized Filter Wheels
- Single Channel Detectors
- Line and Area Detectors
- Data Acquisition Equipment
- Software

# High Resolution Series Monochromators

## DIMENSIONS

Dimensions for 9040 are in [IN].

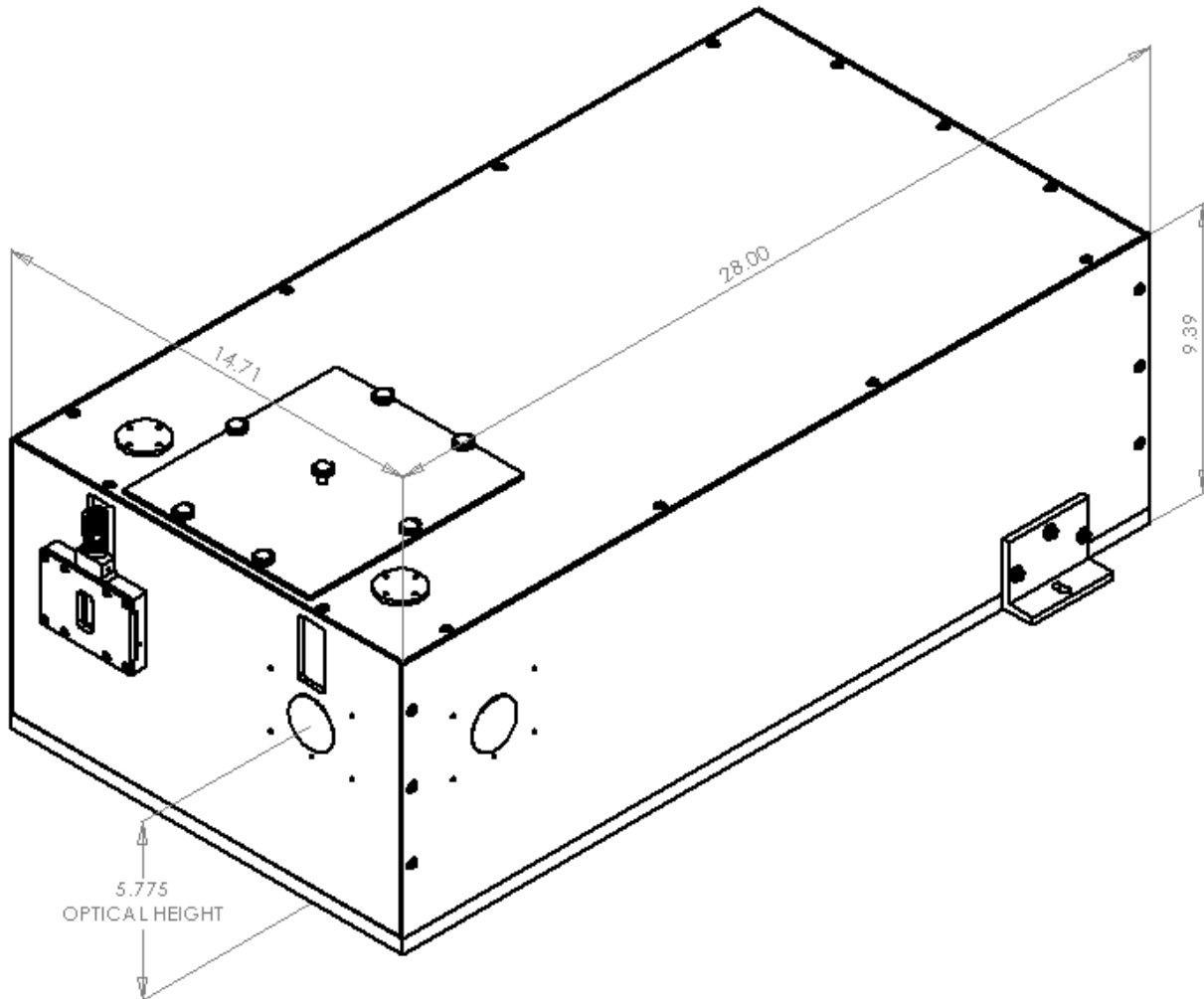

# High Resolution Series Monochromators

## DIMENSIONS

Dimensions for 9490 are in [IN].

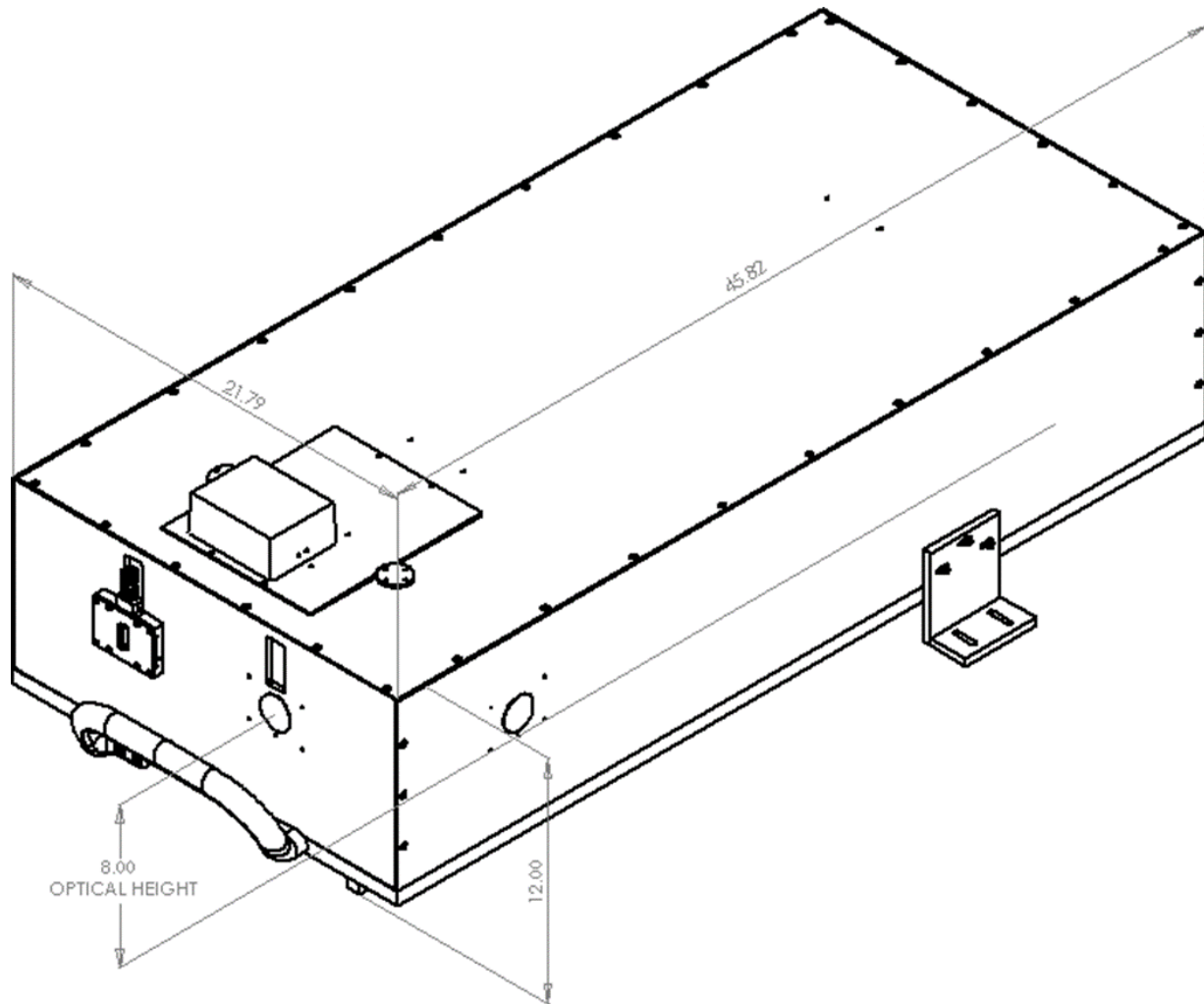

# High Resolution Series Monochromators

## DIMENSIONS

Dimensions for 9150 are in [IN].

